

Industrial Maintenance

Vane Pump

Courseware Sample

37897-F0

Order no.: 37897-70

First Edition

Revision level: 08/2015

By the staff of Festo Didactic

© Festo Didactic Ltée/Ltd, Quebec, Canada 2006

Internet: www.festo-didactic.com

e-mail: did@de.festo.com

Printed in Canada

All rights reserved

ISBN 978-2-89289-970-2 (Printed version)

Legal Deposit – Bibliothèque et Archives nationales du Québec, 2006

Legal Deposit – Library and Archives Canada, 2006

The purchaser shall receive a single right of use which is non-exclusive, non-time-limited and limited geographically to use at the purchaser's site/location as follows.

The purchaser shall be entitled to use the work to train his/her staff at the purchaser's site/location and shall also be entitled to use parts of the copyright material as the basis for the production of his/her own training documentation for the training of his/her staff at the purchaser's site/location with acknowledgement of source and to make copies for this purpose. In the case of schools/technical colleges, training centers, and universities, the right of use shall also include use by school and college students and trainees at the purchaser's site/location for teaching purposes.

The right of use shall in all cases exclude the right to publish the copyright material or to make this available for use on intranet, Internet and LMS platforms and databases such as Moodle, which allow access by a wide variety of users, including those outside of the purchaser's site/location.

Entitlement to other rights relating to reproductions, copies, adaptations, translations, microfilming and transfer to and storage and processing in electronic systems, no matter whether in whole or in part, shall require the prior consent of Festo Didactic.















Information in this document is subject to change without notice and does not represent a commitment on the part of Festo Didactic. The Festo materials described in this document are furnished under a license agreement or a nondisclosure agreement.

Festo Didactic recognizes product names as trademarks or registered trademarks of their respective holders.









All other trademarks are the property of their respective owners. Other trademarks and trade names may be used in this document to refer to either the entity claiming the marks and names or their products. Festo Didactic disclaims any proprietary interest in trademarks and trade names other than its own.

Safety and Common Symbols

The following safety and common symbols may be used in this manual and on the equipment:

| Symbol | Description |
|---|---|
|  | DANGER indicates a hazard with a high level of risk which, if not avoided, will result in death or serious injury. |
|  | WARNING indicates a hazard with a medium level of risk which, if not avoided, could result in death or serious injury. |
|  | CAUTION indicates a hazard with a low level of risk which, if not avoided, could result in minor or moderate injury. |
|  | CAUTION used without the <i>Caution, risk of danger</i> sign  , indicates a hazard with a potentially hazardous situation which, if not avoided, may result in property damage. |
|  | Caution, risk of electric shock |
|  | Caution, hot surface |
|  | Caution, risk of danger |
|  | Caution, lifting hazard |
|  | Caution, hand entanglement hazard |
|  | Notice, non-ionizing radiation |
|  | Direct current |
|  | Alternating current |
|  | Both direct and alternating current |
|  | Three-phase alternating current |

Safety and Common Symbols

| Symbol | Description |
|---|--|
|  | Earth (ground) terminal |
|  | Protective conductor terminal |
|  | Frame or chassis terminal |
|  | Equipotentiality |
|  | On (supply) |
|  | Off (supply) |
|  | Equipment protected throughout by double insulation or reinforced insulation |
|  | In position of a bi-stable push control |
|  | Out position of a bi-stable push control |

We invite readers of this manual to send us their tips, feedback, and suggestions for improving the book.

Please send these to did@de.festo.com.

The authors and Festo Didactic look forward to your comments.

Table of Contents

| | |
|--|-----------|
| Preface | VII |
| About This Manual | IX |
| Work Order 1 Vane Pump | 1 |
| Appendix A Equipment Utilization Chart | 17 |
| Appendix B Safety Procedures | 19 |
| Appendix C Types of Liquid Pumps | 21 |
| Appendix D Variable Speed Drive – Parameter Reference Table | 23 |
| Appendix E Troubleshooting Chart..... | 25 |

To the Instructor

NCCER Accreditation

Contact the National Center for Construction Education and Research (NCCER), at www.nccer.org, to obtain the requirements relative to the NCCER accreditation of this course.

Care and Maintenance of the Pumps Training System

Every week

- Check the general condition of the Pumps Training System.
- Check the condition of the snap-grip clamps on the hoses.
- Make sure the expanding work surface is solidly fixed on the bench. Check the condition of the four (4) push-lock fasteners.

Once a month

- Check the operation of the ground fault circuit interrupter (GFCI).
- Make sure that an O-ring is present and in good condition in each hose coupling.

Every 6 months

- Replace the water in the reservoir.
- Add the following solutions to the water in the reservoir:
 - 2 fl oz (60 ml) of Antibacterial solution, Lab-Volt p/n 38097
 - 8 fl oz (240 ml) of Rust inhibitor, Lab-Volt p/n 38096

Sample Work Order
Extracted from
Vane Pump

Vane Pump

Description

The Vane Pump of your training system is shown in Figure 1-1. It consists of a 4-vane rotor that is positioned eccentrically in a cam ring. As shown in Table C-1 in Appendix C, the Vane Pump is a positive displacement rotary pump. It is also called a sliding vane pump because of the sliding action of the vanes on the cam ring.



Figure 1-1. Vane Pump with and without cover.

How it works

The rotor, which contains radial slots, rotates inside the cam ring. Each slot contains a vane designed to mate with the surface of the cam ring. Push rods keep the vanes out against the surface of the cam ring.

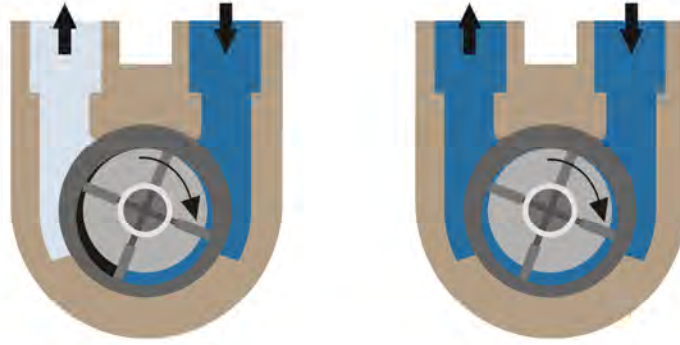

Figure 1-2. Fluid flow in a vane pump.

During one-half revolution of the rotor, the volume increases between the rotor and cam ring. The resulting volume expansion causes a reduction of pressure. This is the suction process, which causes fluid to flow through the inlet port and fill the void.

As the rotor rotates through the second half revolution, the surface of the cam ring pushes the vanes back in their slots, and the trapped volume is reduced. The liquid is squeezed out of the volume and forced out of the discharge port.

Advantages and disadvantages

Advantages: most vane pumps are self priming, have medium capacity, can run dry for short periods, develop a good vacuum.

Disadvantages: they have complex housing, are not suitable for high pressures and abrasive services.

Applications

Vane pumps are used to pump water for carbonated beverage dispensers, post mixing, ultra-filtration, deionized water, recirculation of carbonated water, reverse osmosis, espresso coffee machines, lubrication spraying, insecticide spraying, car wash soap dispensing, distilled water, general laboratory use, fire resistant fluids, hydraulic oil, steam cleaning machines, cooling circulation pressure boosting, atomizing/misting systems, pilot plant, boiler feed, water purification, and fire jockey pumps.

Maintenance

The maintenance required by vane pumps consists in:

- Inspecting the suction strainer periodically, clean or replace as necessary.
- Checking the pump for leakages.
- Inspecting, cleaning, or replacing the components inside the pump.

Characteristics of the Vane Pump of the training system

Maximum speed: 1750 r/min

Maximum discharge pressure: 150 psi (1050 kPa)

Direction of rotation: counterclockwise (when facing the shaft)

Sealing element: mechanical seal

The Vane Pump is fitted with a relief valve to protect the pump and its discharge piping from over pressurization. The pump is also provided with a strainer at the inlet port. See Figure 1-3.



Figure 1-3. A built-in relief valve protects the pump and its piping from over pressurization.

Vane Pump

Task: To identify the components, install, operate, and troubleshoot a vane pump.

PROCEDURE



CAUTION!

Before proceeding with this procedure, complete the safety check list in Appendix B.

- 1. Refer to Figure 1-4 to locate and identify the various components of the Vane Pump.

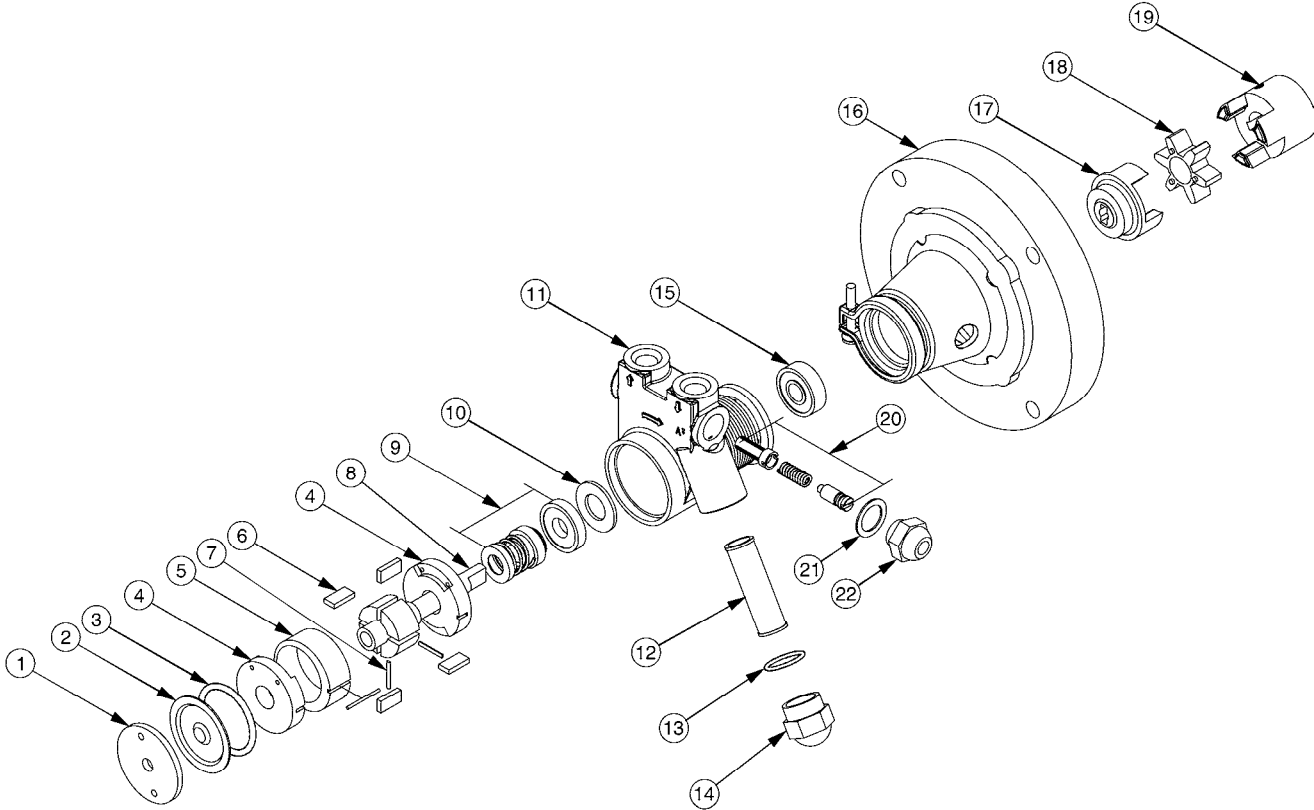

Figure 1-4. Exploded view of the Vane Pump.

| | | | |
|----|--------------------------|----|-----------------------|
| 1 | Cap | 12 | Strainer |
| 2 | Sealing cover | 13 | Seal |
| 3 | O-ring | 14 | Nut |
| 4 | Rotor cap | 15 | Bearing |
| 5 | Cam ring | 16 | Motor adapter |
| 6 | Vane | 17 | Hub (pump) |
| 7 | Push rod | 18 | Insert |
| 8 | Rotor shaft | 19 | Hub (motor) |
| 9 | Mechanical seal assembly | 20 | Relief valve assembly |
| 10 | Washer | 21 | Seal |
| 11 | Housing | 22 | Nut |

Disassembly of the Vane Pump

Note: *The cam ring, rotor caps, and the vanes of the pump are made of carbon graphite. Because this composite is fragile, frequent disassembly is not recommended.*

Instead of disassembling the pump, look at the following figures and answer the questions.

- 2. Figure 1-5 shows the pump after removing the cap, sealing cover, O-ring, and rotor cap.



Figure 1-5. Vane Pump without cap, sealing cover, O-ring, and rotor cap.

What do you observe about the position of the rotor in the cam ring?

- 3. Figure 1-6 shows the components of the rotor assembly.



Figure 1-6. Components of the rotor assembly.

Observe the push rods in Figures 1-5 and 1-6. What are they used for?

Lubrication

Note: The cam ring, rotor caps, and vanes are made of carbon graphite. This composite, which has low friction, excellent corrosion resistance, is capable of operating at temperatures in excess of 315 °C (600 °F) for extended periods of time, and does not require lubrication. A very thin layer of fluid between the vane and the cam ring keeps friction to a minimum.

Circuit setup

- 4. Position the coupling hub on the Motor shaft as shown in Figure 1-7, and tighten the setscrew on the shaft key.

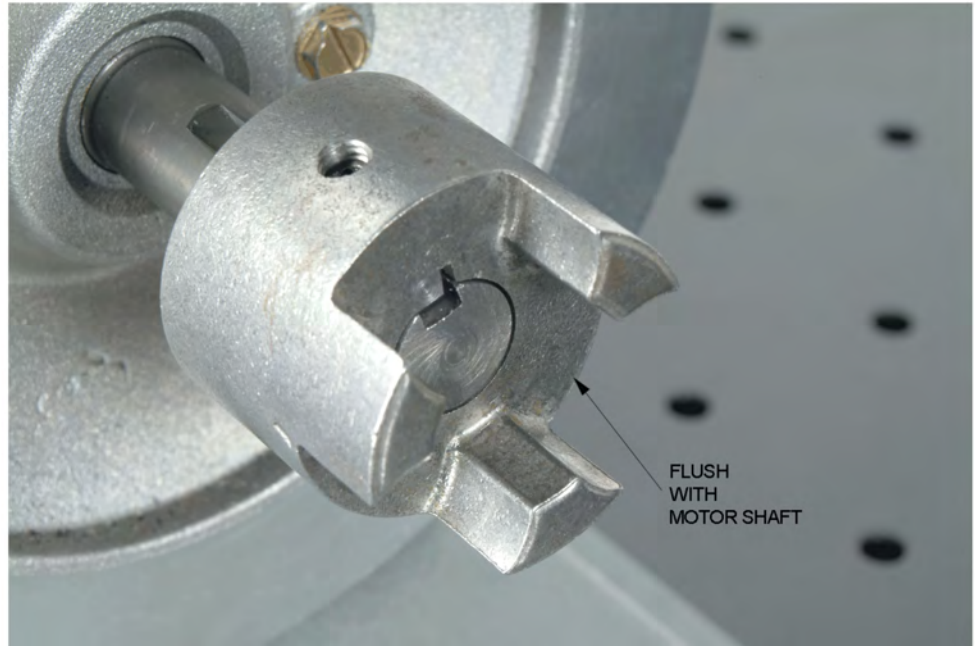

Figure 1-7. Installation of the coupling hub on the Motor shaft.

- 5. Install the insert and second half of the coupling.

- 6. Attach the motor adaptor to the Motor as shown in Figure 1-8.



Figure 1-8. Attach the motor adaptor to the Motor.

- 7. Install the pump and tighten the clamp. Make sure the pump is correctly seated on the motor adaptor before tightening.
- 8. Turn the adjustment screw of the built-in relief valve of the Vane Pump fully clockwise to block the by-pass.
- 9. Set up the pumping circuit shown in Figure 1-9.

Note: Since the flow rate produced by the Vane Pump is below 5 gal US/min (19 l/min), you should use the optional Paddle Wheel Flowmeter (low range), Model 46731.

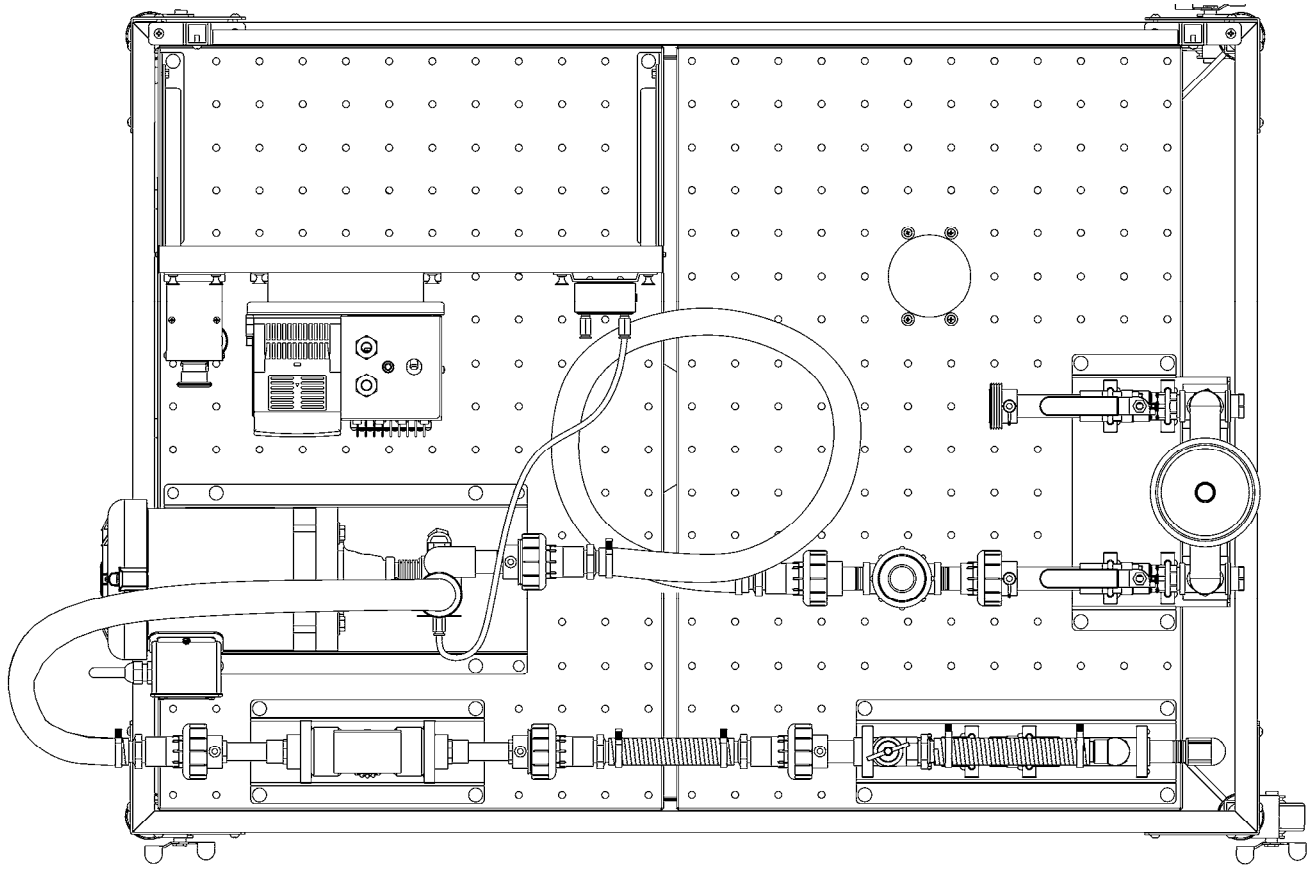

Figure 1-9. Pumping circuit using the Vane Pump.

- 10. Connect the Variable Speed Drive and Motor.
- 11. Perform the following settings on the Variable Speed Drive:
 - Set the maximum output frequency to 30 Hz.
 - Set the direction of rotation to forward.

Note: *The Vane Pump is self-priming.*

- 12. Set the Relief Valve Module to limit the pressure in the circuit to 30 psi (210 kPa) when the output frequency is 30 Hz.

Flow rate versus speed

- 13. Determine the flow rate versus speed (output frequency) characteristics as follows:
 - Open valve HV-4.

- On the Variable Speed Drive, increase the output frequency from 0 to 30 Hz by increments of 5 Hz. For each setting, measure the flow rate and enter your results in Table 1-1.

| OUTPUT FREQUENCY (Hz) | 0 | 5 | 10 | 15 | 20 | 25 | 30 |
|-----------------------|---|---|----|----|----|----|----|
| FLOW RATE | | | | | | | |

Table 1-1. Flow rate versus output frequency.

14. Plot the flow rate versus speed (30 Hz \approx 1725 r/min) curve in Figure 1-10.

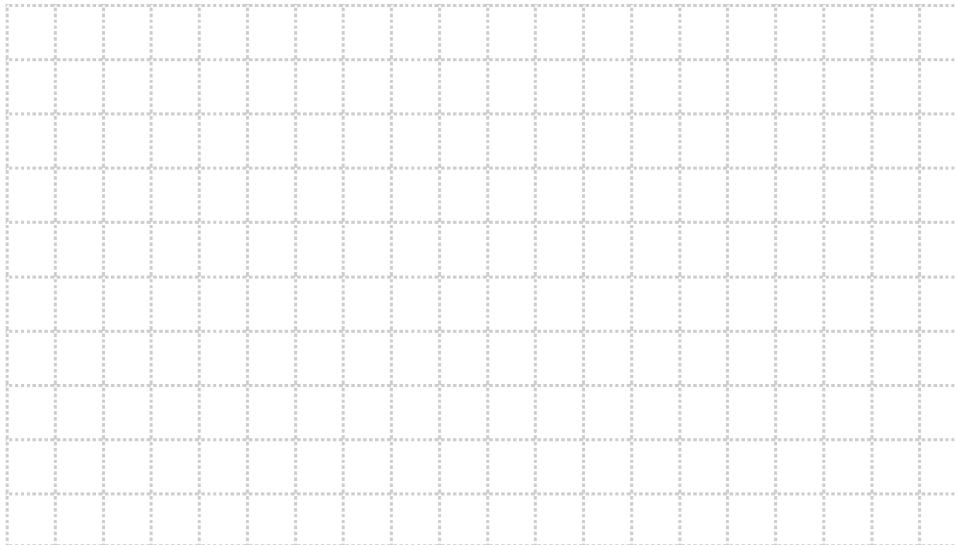

Figure 1-10. Flow rate versus speed curve.

15. From the curve you obtained, describe the relationship between the flow rate and speed.

Head versus flow rate

16. Determine the head versus flow rate characteristics as follows:
- Make sure valve HV-4 is open.
 - On the Variable Speed Drive, set the output frequency to 20 Hz.

- Close valve HV-4 to increase the head by increments of 5 ft (1.5 m) from the current value until HV-4 is fully closed. For each setting, measure the flow rate and enter your results in Table 1-2.
- Repeat your measurements for an output frequency of 30 Hz (increase the head by increments of 10 ft (3 m) for 30 Hz).
- Stop the pump.

| OUTPUT FREQUENCY | | | |
|------------------|-----------|-------|-----------|
| 20 Hz | | 30 Hz | |
| HEAD | FLOW RATE | HEAD | FLOW RATE |
| | | | |
| | | | |
| | | | |
| | | | |
| | | | |
| | | | |
| | | | |
| | | | |
| | | | |
| | | | |

Table 1-2. Head versus flow rate characteristics.

- 17. Plot the head versus flow rate curves in Figure 1-11.

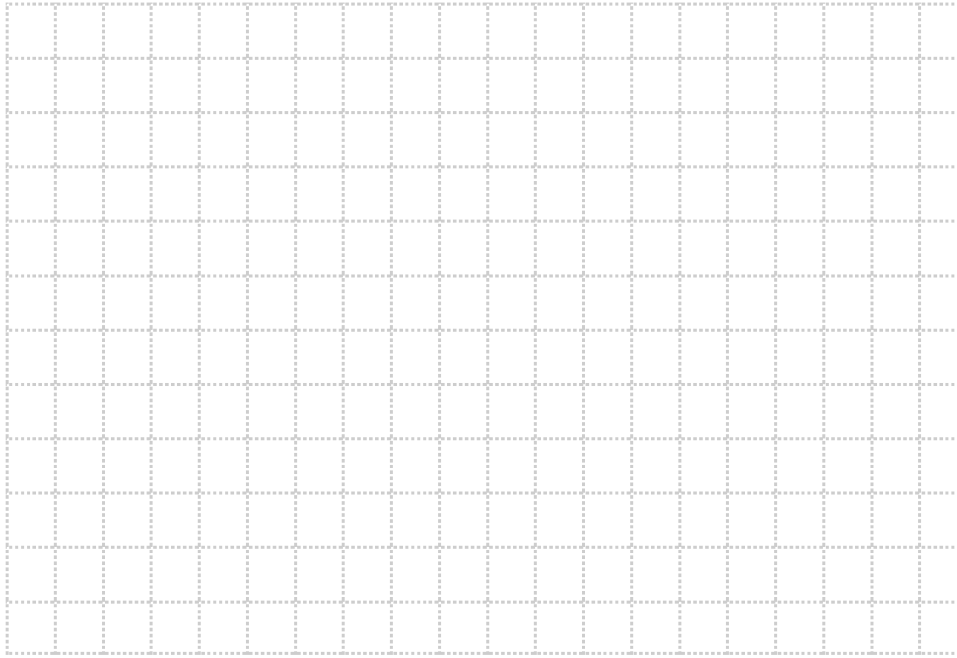

Figure 1-11. Head versus flow rate.

Built-in relief valve setting

- 18. Start the pump.
- 19. Make sure that valve HV-4 is closed and the output frequency is still set to 30 Hz.
- 20. Familiarize yourself with the setting of the built-in relief valve of the Vane Pump by limiting the head to 65 ft (20 m).
- 21. Stop the pump.

Troubleshooting

- 22. By referring to the Troubleshooting Chart in Appendix E, identify two symptoms that the built-in relief valve may cause if it is improperly set.

- 23. By referring to the Troubleshooting Chart in Appendix E, name four possible causes for an unusually low capacity.

- 24. Ask your instructor to check your work.

- 25. Disconnect your setup, and return the equipment to the storage location.

Name: _____ Date: _____

Instructor's approval: _____